

The C-Class

Coupé and Cabriolet



Mercedes-Benz





Captivating and liberating. The C-Class Coupé and Cabriolet.

How intense can a driving experience be today? How emotional is intelligence? Allow yourself to be seduced by the most breathtaking, sensual forms of the automobile. Allow yourself to experience the most intelligent technologies we have ever developed: the AIRMATIC air suspension and the Intelligent Drive assistance systems. Allow yourself to be swept away by the C-Class Coupé and Cabriolet.

INFORMATION AT YOUR FINGERTIPS.

Discover the new C-Class Coupé and the new Cabriolet on your iPad®. The Mercedes-Benz Brochure App containing a wealth of additional content is available free of charge from the iTunes Store®.



Fascination.

2 | Mercedes-Benz C-Class Coupé C 300 selenite grey metallic

AMG Line, AMG multi-spoke light-alloy wheels, panoramic sliding sunroof, saddle brown/black leather upholstery, black open-pore ash/light longitudinal-grain aluminium trim

10 | Mercedes-Benz C-Class Coupé C 250 d 4MATIC designo hyacinth red metallic

5-twin-spoke light-alloy wheels, panoramic sliding sunroof, porcelain/black leather upholstery, black piano-lacquer-look/light longitudinal-grain aluminium trim

16 | Mercedes-Benz C-Class Cabriolet C 400 4MATIC iridium silver metallic

AMG Line, AMG multi-spoke light-alloy wheels, black soft top, cranberry red/black leather upholstery, black open-pore ash/light longitudinal-grain aluminium trim

22 | Mercedes-Benz C-Class Cabriolet C 220 d 4MATIC designo diamond white bright

5-twin-spoke light-alloy wheels, painted himalayas grey with a high-sheen finish, black soft top, saddle brown/black leather upholstery, black piano-lacquer-look/light longitudinal-grain aluminium trim

60 | Mercedes-AMG C 63 S Coupé designo diamond white bright

AMG performance 5-twin-spoke forged wheels, painted matt black with high-sheen rim flange, AMG Night package, AMG Exterior Carbon-Fibre package I + II, red pepper/black AMG nappa leather upholstery, AMG carbon-fibre/light longitudinal-grain aluminium trim

70 | Mercedes-AMG C 63 S Cabriolet designo diamond white bright

AMG performance 5-twin-spoke forged wheels, painted matt black with high-sheen rim flange, AMG Night package, AMG Exterior Carbon-Fibre package I + II, platinum white pearl/black AMG nappa leather upholstery, AMG carbon-fibre/light longitudinal-grain aluminium trim

Innovation.

28 | Mercedes me

32 | Services

36 | Engines, 9G-TRONIC and 4MATIC all-wheel drive

38 | AIRMATIC Agility package and DYNAMIC SELECT drive modes

40 | Mercedes-Benz Intelligent Drive

42 | COMAND Online multimedia system and Remote Online connectivity services

44 | Burmester® surround sound system and cabriolet acoustic innovations

46 | Equipment and packages

56 | Wheels

58 | Mercedes-AMG models

82 | Technical data

85 | Upholstery and paintwork



The embodiment of desire.

The new C-Class Coupé – exciting design for raw emotion. In focus: the striking front end with its sensational diamond radiator grille. And the excitement grows apace with the flowing lines and accentuated shoulders climaxing at the rear. Authentic, powerful, vibrant.



PALAZZO
RENAULT LIND

S C 5205





An image of perfect proportions: with its flat LED tail lamps, the rear of the new C-Class Coupé exudes breadth and agility. A defining feature of a genuine coupé with such a progressive profile: the frameless doors with free-standing exterior mirrors. And while you may long to keep looking at it, the desire to experience the C-Class Coupé in full flow is simply too strong to resist.



More than worthy
of attention.



Everything is focussed on you. The instruments are perfectly arranged – their operation simply intuitive. An optional Head-up Display projects the most important information into your field of view. This could be the current speed, the applicable speed limit or navigation instructions, depending on the car's equipment. You perceive the information hovering above the bonnet around two metres in front of your eyes.



In tight bends and in fast curves: the coupé seats with integral head restraints offer ideal lateral support and a sporty look with powerful colours. In keeping with the low sitting position, the exterior mirrors are positioned directly on the frameless doors – a hallmark of fascinating coupé design.







Your pulse races away –
reel it back in.



The summit. Finally you catch your breath. All of a sudden you pause. And cast your eyes over the exclusive look of the high-quality interior. From the dynamically designed centre console to the controls and trim in silver chrome. Your hands feel the pleasant touch of choice materials. Then you grasp the 3-spoke multifunction steering wheel. And continue on your quest for curves.







Expect the most intensive
365 days of the year.





Return of a blazing star.

The emotionally charged lines and muscular surfaces of the new C-Class Cabriolet display breathtaking style. Surpassed only by the driving experience: options such as 4MATIC all-wheel drive or AIRMATIC air suspension make for thrilling dynamism. Then open the fully automatic fabric soft top to experience unbridled driving enjoyment. Unique equipment in this class like the AIRCAP automatic draught-stop system and AIRSCARF neck-level heating emphasise the fact that Cabriolet begins with C.





Sharpness in motion.

The new C-Class Cabriolet positively exudes acceleration: the diamond radiator grille is an exclusive statement of pure driving pleasure. Distinctive design lines on the bonnet point in one direction only: forwards. Towards the large air intakes and the standard-fit LED High Performance headlamps which are the crowning glory of the assertive design.



The image shows the interior of a car, focusing on the driver's side. The seats are upholstered in a rich, reddish-brown leather with a pebbled texture. The headrests are integrated into the seat design. The car's interior panels, including the door and center console, also feature the same leather. Through the open top of the car, a vibrant autumn scene is visible, with trees in shades of red and orange. In the background, a modern city skyline with tall glass buildings is partially visible under a clear sky.

One of the most alluring aspects of open-top driving is the look inside.

An interior like an invitation: come inside, breathe in, be free. Sporty seats with integral head restraints, a low sitting position and a pure open-air experience ramp up the emotive appeal and intensity with each passing mile. High-class equipment and appointments options further refine the interior: sun-reflecting leather seats, a breathtaking Burmester® surround sound system and Mercedes me connect for digital connectivity.

Take a deep breath.

Summer is your constant companion all year round. With highly intelligent cabriolet features such as the AIRCAP automatic draught-stop system and AIRSCARF neck-level heating available as options, you can be sure of unbridled open-air enjoyment in practically any weather. Rain clouds gathering? The fully automatic fabric soft top can be opened and closed whilst driving at up to 50 km/h.



Before your
breath is taken away.

Shooting up the open-ended adrenaline scale.

The road ahead is clear, so the powerful engine can do what it does best: effortlessly superior acceleration. As you steer into the next bend, the new C-Class Cabriolet barely twitches, remaining remarkably stable and right on track. All you feel is impressive traction, poise and assurance – even in poor road conditions. There's little that can halt this surge of dynamism when the most advanced drive and suspension systems are on board: 4MATIC all-wheel drive, AIRMATIC air suspension and the DYNAMIC SELECT drive modes – a unique package of technology in this class.



The image shows the interior of a car, focusing on the front passenger seat and the rear seat. The seats are upholstered in a light brown, perforated leather. The car's interior is finished with dark grey or black panels on the door and rear side. The car is parked on a rooftop or elevated platform, offering a panoramic view of a city skyline with numerous skyscrapers and a row of trees with vibrant red autumn foliage in the foreground.

More than a cockpit: an open-air stage.

Perfectly matched materials and colours exude sporty lifestyle. Choose from a range of exclusive upholstery colour combinations such as sun-reflecting leather in saddle brown/black or porcelain/black, designo nappa leather in Bengal red/black, and an array of fine trim finishes. As a true driver's car, the cockpit is designed around the person behind the wheel. Door and rear side panelling sections flow smoothly into each other and underscore the dynamic character.





Our world in your hands.

www.mercedes.me – it's all about you. Discover a world of fascinating services, products and innovations which will enrich your life and take the strain out of everyday mobility. Coming straight to you in digital form. And turning our world into your world.





Life can be so fascinating when you're fully connected.

All our connectivity and mobility services plus a host of other fascinating features – all in one place and exclusively for you. That's Mercedes me. Register free of charge today and make the world of Mercedes-Benz your very own at your convenience – on your PC or laptop or in mobile mode via tablet, smartphone or smartwatch. And because your life is forever changing, our services are also continually evolving. Join us now at www.mercedes.me/welcome

Looking for individual inspiration in real life, too? The Mercedes me Stores are a fascinating phenomenon worldwide – in Beijing, Moscow and Hamburg, for example.



Mercedes me connect networks you with your vehicle – and your vehicle with the whole world. A comprehensive range of convenient connectivity services relating to all areas of your vehicle supports you, ensuring greater safety, closer contact and an even more fascinating driving experience. It's reassuring to stay connected all the time while you're on the move. Mercedes me connect includes Standard Services, which are able to provide you with automatic support in the event of a breakdown or an accident, and Remote Online Services – the option enabling vehicle settings to be carried out by smartphone – and lots more besides.

Mercedes me inspire offers special brand experiences and an opportunity to engage in an inspiring dialogue. We aim to share our ideas with you and we would like to know your ideas and wishes. So that we can always offer you the best solutions. A community is available to this end, and you will also find a growing range of offerings and experiences which go beyond the traditional vehicle-related topics – from areas such as events, travel and lifestyle.

Mercedes me move offers access to intelligent mobility solutions: car2go is the pioneer and global market leader in free-floating car sharing, the moovel mobility app pools the offerings from various mobility providers to find the ideal route from A to B. With the mytaxi app you can order a taxi, track its approach live and pay for your journey in a convenient manner. Mercedes-Benz Rent offers vehicles to suit all occasions for short- or long-term rental from an authorised Mercedes-Benz dealer near you. Blacklane enables you to book a chauffeur-driven limousine, FlixBus offers inexpensive, comfortable and environment-friendly trips on long-distance coaches.

Mercedes me assist makes easy work of organising maintenance for your vehicle, providing a convenient online means of locating a Mercedes-Benz dealer in your neighbourhood and arranging a service appointment. The digital service report keeps you up to date on performed service work at all times. The report is available to you online just one day after a service. In addition to the current service report, you can also view your vehicle's complete service history and service intervals, and you can print this information out if you so wish.

Mercedes me finance offers you various routes to your vehicle of choice. The Mercedes-Benz Bank/Mercedes-Benz Financial Services finds the ideal leasing, financing and insurance solution together with you – tailored to your needs. Our leasing products enable you to drive the latest models at all times while enjoying maximum flexibility, as you pay not for acquisition of the vehicle, but only for its use. You also benefit from attractive monthly instalments. Our financing arrangements enable you to pay for your new Mercedes-Benz in a way that suits your personal budget. You can tailor your monthly instalments to your needs by deciding on an appropriate down-payment and term for your contract. Our individual insurance solutions offer reliable protection for your budget and your vehicle on attractive terms. Once a contract is in place, you can conveniently manage your finance applications online.¹

¹ Depending on market availability.

**Mercedes-Benz
Service**



Our service: the perfect fit for your Mercedes.

Beyond the car itself, you also acquire something priceless – an exclusive partnership with Mercedes-Benz. For you, this means safety, independence and motoring free of any worries. In other words: the reassuring feeling of driving a Mercedes.

The best for your Mercedes. No-one knows your Mercedes better than our experienced specialists at the Mercedes-Benz workshops. The comprehensive range of services and the high standard of quality ensure that your vehicle is in top condition. We use proven Mercedes-Benz GenuineParts and special tools to this end.

The best for you. Motoring free of any worries right from the word go: with the tailor-made Mercedes-Benz Service Contracts. These offer you the benefits of a reliable basis for long-term planning, permanent control over costs, fixed monthly rates and cost transparency. Plus ideal protection from additional workshop costs.

The best for your mobility. The Mercedes-Benz Mobilo¹ mobility solution provides for motoring free of any worries throughout Europe – covering breakdowns, accidents, minor mishaps and vandalism. The benefits offered by Mobilo include on-the-spot assistance, a replacement vehicle, towing and overnight hotel accommodation, for example. Mobilo comes free of charge for the first two years after initial registration and can subsequently be renewed each time the vehicle is serviced by an authorised service partner, for a period of up to 30 years in all. Whenever you need assistance, you can reach us free of charge throughout Europe on 00800 1 777 7777².

↘ FIND OUT MORE

For the full information on Mercedes-Benz Service Contracts, go to www.mercedes-benz.com/servicevertraege – or ask your authorised Mercedes-Benz dealer to draw up an individual offer for you.

¹ Our general terms and conditions apply. The period of validity is extended after each service carried out by an authorised Mercedes-Benz service partner until the due date for the next service – up to a maximum of 30 years after initial registration. ² Roaming charges may apply when calling from abroad.

What would motorsport be without Mercedes-Benz?

The first vehicle ever to win an automobile race was powered by a Daimler engine. The first Mercedes was a racing car. The Silver Arrows – a true legend. Mercedes-Benz has a long tradition of involvement with the world of sport. Motorsport shapes the brand and every vehicle bearing the Mercedes star to this day. Discover the brand's unique history first-hand: at the Mercedes-Benz Museum in Stuttgart.

↘ FIND OUT MORE

Discover just what has been moving the world for 130 years and take a journey through time as well as through the history of the automobile at the Mercedes-Benz Museum. More than 1500 exhibits await you on 16,500 m² of floorspace, including unique gems such as the oldest surviving Mercedes from 1902 or the legendary gull-wing models. Welcome to a place of innovation:

www.mercedes-benz.com/museum

www.facebook.com/mercedesbenzmuseum

www.instagram.com/mercedesbenzclassic

www.twitter.com/mb_museum

www.google.com/+mercedesbenzmuseum

www.youtube.com/mercedesbenzmuseum



What would Mercedes-Benz be without motorsport?

3 June 1934 marked the beginning of the Silver Arrows legend in the International Eifel Race at the Nürburgring. Today this legend is more alive than ever: in 2015 the Silver Arrows works team MERCEDES AMG PETRONAS won the Formula 1 constructors' and drivers' titles for the second year in a row. The value of these successes extends way beyond the race track: every mile raced advances the development of lightweight materials and hybrid technology, for example, for application in series production.

↘ FIND OUT MORE

Fascinating Formula 1 goes multimedia:
www.facebook.com/MercedesAMGF1
www.twitter.com/MercedesAMGF1
www.youtube.com/MercedesAMGF1
www.google.com/+MercedesAMGF1
www.instagram.com/MercedesAMGF1
www.MercedesAMGF1.com
www.mercedes-benz.com/motorsport



Mercedes-Benz F1 W07 hybrid, 2016 season.



Acceleration that doesn't cost the earth.

The new C-Class Coupé and Cabriolet are driven by true sporting hearts. The **C 300** is rated at 180 kW (245 hp). Its weight-optimised design with exhaust-gas turbocharger ensures reduced consumption and thus low emissions – while delivering a significantly higher output and more torque than the previous engine generation.

THE ENGINE RANGE

Petrol

C 180 with an output of 115 kW (156 hp) and a peak torque of 250 Nm

C 200 with an output of 135 kW (184 hp) and a peak torque of 300 Nm

C 200 4MATIC with an output of 135 kW (184 hp) and a peak torque of 300 Nm

C 250 with an output of 155 kW (211 hp) and a peak torque of 350 Nm

C 300 with an output of 180 kW (245 hp) and a peak torque of 370 Nm

C 400 4MATIC with an output of 245 kW (333 hp) and a peak torque of 480 Nm

Diesel

C 220 d with an output of 125 kW (170 hp) and a peak torque of 400 Nm

C 220 d 4MATIC with an output of 125 kW (170 hp) and a peak torque of 400 Nm

C 250 d with an output of 150 kW (204 hp) and a peak torque of 500 Nm

C 250 d 4MATIC with an output of 150 kW (204 hp) and a peak torque of 500 Nm (Coupé only)

Relentless drive.

if you've ever experienced the comfort, dynamics and, most of all, the driving safety of an all-wheel drive, you won't want to do without it ever again. Be it during powerful acceleration, on speedy straight-ahead stretches or, and that goes without saying, slippery road surfaces: the advantages are tangible in almost any driving situation.

4MATIC permanent all-wheel drive improves traction and driving stability with a permanent rear-biased power distribution of 45 : 55 – especially in difficult road conditions. An exceptionally compact lightweight design optimises efficiency and agility.



Automatic exhilaration.

Impressively sporty performance, relaxing comfort and contemporary efficiency – it all comes automatically to the C-Class Coupé and Cabriolet. The **9G-TRONIC 9-speed automatic transmission** is standard or optional, depending on the chosen engine. Fast, almost imperceptible gear changes allow maximum spontaneity and agility. The transmission can also jump gears, enabling multiple downshifts for powerful, swift bursts of speed.







Air supremacy - the AIRMATIC Agility package.

Experience sheer agility and unique driving pleasure: with the specially developed AGILITY CONTROL suspension for enhanced suspension and ride comfort as well as dynamic performance – and with the optional **AIRMATIC Agility package**. The air suspension with continuously variable damping system operates fully automatically. The damping at each wheel is adapted to the current driving situation and road surface condition.

A flick of the **DYNAMIC SELECT** Controller is all it takes to apply a different type of power: individuality. To achieve this, parameters such as the engine, suspension (in conjunction with the optional AIRMATIC Agility package) and steering characteristics are adjusted according to the selected drive mode. The **9G-TRONIC automatic transmission** also changes the gearshift characteristics. Five modes provide just the type of drive required, with the focus on fuel efficiency, comfort or agility. As its name suggests, “Sport+” places the emphasis firmly on sport – with more progressive steering characteristics, stiffer sports-tuned suspension and modified shift points.

FURTHER SUSPENSION OPTIONS

The combination of **AIRMATIC** air suspension with the **DYNAMIC SELECT** Controller allows you to create a driving experience to suit your needs or preferences. Five different drive modes are available at the touch of a button – very comfortable, sporty, very sporty and efficient. An entirely individual setting is also possible. The selected drive mode is shown on the instrument cluster and on the media display.

A tauter spring and damper setting makes a more dynamic driving style possible with the **sports suspension with Sports Direct-Steer system** – a sporty variant of the AGILITY CONTROL suspension. The selective passive damping system continues to ensure a high level of comfort.

On the road to accident-free driving. Mercedes-Benz Intelligent Drive.

Mercedes-Benz Intelligent Drive assists when it matters. Attentively and in full control, without missing a thing. Intervening where necessary. Holding back where possible. This effortless superiority is part of the optional **Driving Assistance package Plus**: a combination of intelligent driving assistance and safety systems which can help the driver and make driving tangibly easier.

DISTRONIC PLUS with Steering Assist and Stop&Go Pilot helps you keep a safe distance from the vehicle in front and also stay in lane. **BAS PLUS** Brake Assist with Cross-Traffic Assist and **PRE-SAFE® Brake** can reduce the risk of accidents at junctions, rear-end collisions and collisions with pedestrians, particularly in urban traffic. **Active Lane Keeping Assist** and **Active Blind Spot Assist** provide assistance if the vehicle leaves its lane unintentionally or during lane changes if there is a danger of collision with other vehicles. **PRE-SAFE® PLUS** extends the functions of the **PRE-SAFE®** occupant protection system with preventive measures when a rear impact threatens.



MERCEDES-BENZ INTELLIGENT DRIVE

A stereo camera, short- and long-range radars, and all-round sensor systems form the basis for numerous safety and assistance systems in the C-Class Coupé and Cabriolet.

- 1 | Stereo multi-purpose camera. 2 | Long-range radar with intermediate range sensing.
- 3 | Short-range radar. 4 | Ultrasonic sensors.
- 5 | Multi-mode radar. 6 | 360° camera.

The reassuring feeling of driving a Mercedes-Benz.

Mercedes-Benz was the world's first automotive manufacturer to develop an **integral safety concept**, aimed at avoiding accidents, ensuring ideal responses to dangers and lessening the consequences of accidents. For the occupants of a Mercedes-Benz and for all other road users, too.

SAFE DRIVING

ATTENTION ASSIST, which comes as standard, can improve handling safety, especially on long journeys and at night. It can monitor the driver's steering behaviour to detect typical signs of drowsiness and give a visual and audible warning of impending microsleep.

IN THE EVENT OF DANGER

Active Lane Keeping Assist can detect when the car leaves its lane unintentionally, warn the driver by making the steering wheel vibrate and actuate the brakes on one side to help manoeuvre the vehicle back into its lane.

Active Blind Spot Assist makes one of the greatest sources of danger in road traffic visible – vehicles in the blind spot. When the car changes lane, for example, it can warn the driver and help prevent an imminent collision by applying the brakes on one side of the vehicle.

Active Lane Keeping Assist and Active Blind Spot Assist form part of the optionally available **Driving Assistance package Plus**.

COLLISION PREVENTION ASSIST, fitted as standard, gives the driver a visual warning if the distance to the vehicle travelling ahead or to a stationary object is too short. On detecting the danger of a collision, driver braking can be assisted and, if the driver fails to react, the speed can be reduced autonomously.

The optionally available **PRE-SAFE®** anticipatory occupant protection system is able to identify critical driving situations in advance and to initiate precautionary measures to protect the vehicle's occupants if an accident appears imminent. Such measures include reversible belt tensioning or automatic closing of open side windows, for example.

IN AN ACCIDENT

On many model variants, the **active bonnet** can be raised when a pedestrian or cyclist collides with the front of the car. The increased distance from the components inside the engine compartment creates an additional deformation space to absorb the impact sooner and reduce the risk of injury.

AFTER AN ACCIDENT

If the worst comes to the worst, the engine can be stopped automatically, the hazard warning lamps and emergency interior lighting can be activated, and the central locking can be unlocked. Finally the integrated **Mercedes-Benz emergency call system** can send GPS position data and important vehicle information.

↳ BETTER SAFE THAN SORRY

Informative animated films covering nearly all of the safety technologies are available from the Mercedes-Benz TechCenter.
<http://techcenter.mercedes-benz.com>

WE ARE HERE TO HELP

Should you require assistance en route, you can call Mercedes-Benz Service24h free of charge on 00800 1 777 7777. When connected to a mobile phone, the integrated telematics service Mercedes-Benz Contact can even connect you to our after-sales service automatically as well as relaying relevant vehicle and position data.



All linked up. The world at your fingertips.

Current information, extensive communication and top-level entertainment: the multimedia systems in the C-Class Coupé and Cabriolet indulge your every wish. The optional **COMAND Online** system offers real-time navigation, internet access and first-class music enjoyment, for example. **Remote Online** lets you stay in contact with your vehicle via smartphone – for example thanks to the Parked Vehicle Locator function and Remote Door Locking and Unlocking.

Simple gestures are all it takes to operate COMAND Online – via **touchpad with multi-touch sensor system**. All it needs to understand your wishes is one or two finger movements – a quick swipe or a splay. It can even decipher the letters and numbers in your handwriting.

COMAND Online. Navigation, telephone, audio, video, internet – with the optional control and display system the driver has direct access to these and many other functions. Information is shown in high resolution and in colour on a 21.3 cm (8.4-inch) media display. Controlling the system using the new touchpad with multi-touch sensor system is easy and intuitive.

Audio 20 CD with touchpad. This optional multimedia system combines entertainment, information and communication. The Audio 20 CD with internet capability, radio, twin tuner, CD drive and 17.8 cm (7-inch) media display also allows networking with mobile devices via Bluetooth®.

The optional **Head-up Display** projects important information within the driver's field of view – such as speed and, depending on equipment, speed limits, navigation instructions and assistance systems. The driver perceives the information hovering above the bonnet around two metres in front of the eyes.





Music to your ears.

The optional **Burmester® surround sound system** indulges even the most demanding of listeners: enjoy an exceptional sound experience composed of 13 high-performance loudspeakers, a surround function, a 9-channel DSP amplifier and an output of 590 watts.

To minimise exterior noise disturbance, the C-Class Cabriolet comes with the option of a **fabric acoustic soft top** – for a low noise level almost on a par with that of the C-Class Coupé. For the ultimate in musical enjoyment even when travelling at high speed.

OPTIONAL EXTRAS FOR UNIQUE OPEN-TOP DRIVING COMFORT

When driving with the roof down, the automatic **AIRCAP draught-stop system** reduces air turbulence in the vehicle interior for all passengers, including those in the rear seats. When the AIRCAP switch is operated, a wind deflector is deployed on the windscreen and the draught-stop located between the two rear seat headrests is raised.

The **fully automatic fabric acoustic soft top** features a multilayer composition with acoustically effective insulating and damping materials. It meets the highest requirements in terms of climate and noise comfort. The fabric acoustic soft top is available in the colours black, dark blue, dark brown and dark red.

The **AIRSCARF neck-level heating** for the driver and front passenger makes open-top motoring a pleasure, even when the outside temperature is low. Through air outlets in the head restraints, pleasantly warm air is “wrapped” around the necks of the driver and front passenger like an invisible scarf. The desired intensity can be adjusted in three levels.







Immediate appeal: the standard equipment.

Even the standard version of the C-Class Coupé and Cabriolet causes quite a stir – featuring a diamond radiator grille with pins in black, 43.2 cm (17-inch) light-alloy wheels and lots more besides.

↘ FIND OUT MORE

The full range of standard equipment can be found in the price list, which can also be viewed online.

EXTERIOR HIGHLIGHTS

Diamond radiator grille with pins in black and a single louvre in matt iridium silver

LED High Performance headlamps (Cabriolet only)

LED tail lamps with four horizontal LED light strips

Frameless doors with free-standing exterior mirrors

Trim in polished aluminium

AGILITY CONTROL lowered suspension

10-spoke light-alloy wheels with 225/50 R 17 tyres

INTERIOR HIGHLIGHTS

Coupé and Cabriolet seats with integral head restraints, with individual seats in the rear

Automatic belt feeders (Cabriolet; optional for Coupé)

3-spoke multifunction steering wheel in black leather

Trim in piano-lacquer look

Folding rear seat backrests

ARTICO man-made leather/black Norwich fabric upholstery

Roof liner in crystal grey fabric

Fully automatic fabric soft top in black (Cabriolet)



Perfectly defined: the AMG Line.

AMG. As sporty and dynamic as it gets. The powerful AMG Line with the striking AMG bodystyling cuts a fine figure from any angle.

PURE AMG

Experience the sheer fascination of AMG starting on page 58.

EXTERIOR HIGHLIGHTS

AMG bodystyling, consisting of AMG front apron, AMG side sill panels and AMG rear apron

AMG 5-spoke light-alloy wheels, painted titanium grey with a high-sheen finish, with 225/45 R 18 front tyres and 245/40 R 18 rear tyres

Optional: AMG multi-spoke light-alloy wheels, painted titanium grey with a high-sheen finish, with 225/40 R 19 front tyres and 255/35 R 19 rear tyres

Diamond radiator grille with chrome pins and an integral Mercedes star

Lowered sports suspension and Sports Direct-Steer system

Exhaust system with two visible tailpipe trim elements integrated into the bumper

INTERIOR HIGHLIGHTS

ARTICO man-made leather/black DINAMICA microfibre upholstery

3-spoke multifunction sports steering wheel with flattened bottom section, in black leather, with heavily perforated grip areas

Instrument cluster with two tube-shaped round dials

Black open-pore ash wood/light longitudinal-grain aluminium trim

AMG brushed stainless-steel sports pedals

Roof liner in black fabric

Interior Light package for more atmosphere and safety





Immediate inspiration: the optional extras.

More light and more atmosphere. More safety and more comfort. More stylish and more accommodating. It's all possible – with the optional extras for the C-Class Coupé and Cabriolet.

OTHER OPTIONAL HIGHLIGHTS

With its large glass surfaces, the optional **panoramic sliding sunroof** creates an exceptionally light and friendly ambience inside the C-Class Coupé.

The **LED Intelligent Light System** facilitates optimum vision: with variable light distribution, active light function, country mode, motorway mode, cornering light function, enhanced fog light function, dynamic beam control and a blue welcome light.

Reverse parking and manoeuvring is made much easier and safer by the **reversing camera**. It is activated automatically when reverse gear is engaged and shows the area behind the vehicle on the display with dynamic guidance lines.

The perfect setting: with its pleasant, indirect light and illuminated door sill panels, the optional **ambient lighting** creates a unique atmosphere throughout the entire interior. There are three different colours and five dimming levels from which to choose.

The **electrically adjustable front seats with Memory function** provide comfortable and individual adjustment of seating and head restraint positions. Settings can be stored and called up at any time for up to three people.

Active Parking Assist makes finding a parking space as well as parking in both parallel and perpendicular spaces easier; it also assists when leaving a parallel parking space. The system automatically steers the vehicle into parking spaces, relieving the driver of the work of steering and braking.





Sporty and individual: the Style package.

The Style package for the C-Class Coupé comprises a host of perfectly coordinated items of equipment to enhance the sportiness and individuality of the vehicle even further. The seats with an integral design typical of a coupé create a highlight with nut brown/black upholstery in ARTICO man-made leather/DINAMICA microfibre and feature-accentuating topstitching in turquoise.

HIGHLIGHTS AT A GLANCE

Seats upholstered in ARTICO man-made leather/DINAMICA microfibre in two-tone black/nut brown with contrasting topstitching in turquoise

Door centre panels, armrests in the doors and centre armrest in ARTICO man-made leather in nut brown with contrasting topstitching in turquoise

Floor mats with edging in nut brown and contrasting topstitching in turquoise

Roof liner in black fabric

A dream in Bengal red. The designo interior.

designo is the name of our world for the truly special. An exclusive interior featuring upholstery in designo Bengal red/black nappa leather is available for the C-Class Coupé and Cabriolet. It creates an expressive, sporty ambience with high-quality details such as a diamond design, patterned perforations and contrasting topstitching.

Experience this mesmerising design at first hand. Your authorised Mercedes-Benz dealer will be happy to advise you using genuine samples.

HIGHLIGHTS AT A GLANCE

Seats in designo nappa leather in Bengal red/black with seat backrests and cushions in a diamond design with patterned perforations, seat side bolsters and head restraints with contrasting topstitching in black

Door centre panels in a diamond design, door armrests and centre armrest in ARTICO man-made leather in nappa look

Upper part of dashboard and beltlines in ARTICO man-made leather in black with contrasting topstitching

“designo” badges in the backrests of the front and rear seats

designo velour floor mats with black edging in nappa-look ARTICO man-made leather with red contrasting topstitching as well as “designo” badges on the front floor mats





Charged with excitement. The Night package.

Striking design elements in black underscore the sporty, expressive character of the C-Class Coupé. Design features such as the dark-tinted windows starting from the B-pillar and black-painted light-alloy wheels with a high-sheen finish create expressive highlights. The Night package is perfectly matched to the AMG bodystyling and only available in conjunction with the AMG Line.



HIGHLIGHTS AT A GLANCE

AMG front apron with trim in high-gloss black

Diamond radiator grille with pins in chrome and integral Mercedes star with louvre in high-gloss black and chrome insert

Heat-insulating dark-tinted glass starting from the B-pillar

AMG 5-spoke light-alloy wheels, painted high-gloss black with a high-sheen finish, with 225/45 R 18 front tyres and 245/40 R 18 rear tyres

AMG multi-spoke light-alloy wheels, painted high-gloss black with a high-sheen finish, with 225/40 R 19 front tyres and 255/35 R 19 rear tyres (optional)

Rear apron with diffuser in high-gloss black

Exterior mirrors painted in black (painted in body colour in conjunction with obsidian black metallic)

Beltline trim strip and window weatherstrip in high-gloss black

Often copied - never matched: Genuine Accessories.

Ideally prepared for the next weekend trip or everyday challenges: thanks to Mercedes-Benz Genuine Accessories. Discover the entire range at www.mercedes-benz-accessories.com

HIGHLIGHTS AT A GLANCE

The harmoniously integrated **roof spoiler** and the discreet **rear spoiler** give the Coupé an even sportier look.

10-spoke light-alloy wheels, painted black, rim flange with high-sheen finish, with 225/40 R 19 front tyres and 245/35 R 19 rear tyres.

The **Alustyle basic carrier bars** in Mercedes-Benz design are precisely matched to the body of the C-Class Coupé. They serve as a basis for many Mercedes-Benz transport solutions and are easy to mount. Crash-tested and lockable.

The **Comfort ski and snowboard rack** for the C-Class Coupé is suitable for up to six pairs of skis (depending on the ski geometry) or four snowboards. The practical pull-out function makes loading and unloading easier. Lockable.

The easy to fit and use, lockable **rear-mounted cycle rack** allows the safe transport of two or three bicycles. It is mounted on the trailer coupling. Maximum load of up to 30 kg per bicycle rail, also suitable for e-bikes. Thanks to an ingenious roller mechanism the boot can still be opened. When the rack has been removed it can be folded up for easy storage in the boot, holiday accommodation or home.





25R



R11



22R R17



R48



R32



R90 R97



The perfect way to round off your style.

Wheels are indispensable on technical grounds, of course. But on an emotional level, too, perfect wheels are an absolutely crucial ingredient of many people's dream car. So we have compiled an attractive selection for you.

STANDARD EQUIPMENT AND OPTIONAL EXTRAS

25R 10-spoke light-alloy wheels, painted vanadium silver, with 225/50 R 17 tyres (standard equipment except for Mercedes-AMG models)

R48 5-twin-spoke light-alloy wheels, painted himalayas grey with a high-sheen finish, with 225/50 R 17 tyres (option; not available for Mercedes-AMG models)

R11 5-twin-spoke light-alloy wheels, painted vanadium silver, with 225/50 R 17 tyres (option; not available for Mercedes-AMG models)

R32 5-spoke light-alloy wheels, painted vanadium silver, with 225/45 R 18 front tyres and 245/40 R 18 rear tyres (option; not available for Mercedes-AMG models)

22R 5-twin-spoke light-alloy wheels, painted himalayas grey with a high-sheen finish, with 225/45 R 18 front tyres and 245/40 R 18 rear tyres (option; not available for Mercedes-AMG models)

R90 5-twin-spoke light-alloy wheels, painted himalayas grey with a high-sheen finish, with 225/40 R 19 front tyres and 245/35 R 19 rear tyres (option; not available for Mercedes-AMG models)

R17 5-twin-spoke light-alloy wheels, painted tremolite grey with a high-sheen finish, with 225/40 R 19 front tyres and 245/35 R 19 rear tyres (option; not available for Mercedes-AMG models)

R97 10-spoke light-alloy wheels, painted himalayas grey with a high-sheen finish, with 225/40 R 19 front tyres and 245/35 R 19 rear tyres (option; not available for Mercedes-AMG models)



782



604
644



601



57

662
767



788
605
665
606



609



770
766



RXC

AMG

782 AMG 5-spoke light-alloy wheels, painted titanium grey with a high-sheen finish, with 225/45 R 18 front tyres and 245/40 R 18 rear tyres (part of the optional AMG Line; available as standard as wheel 661 painted high-gloss black for Mercedes-AMG C 43)¹

788 AMG multi-spoke light-alloy wheels, painted titanium grey with a high-sheen finish, with 225/40 R 19 front tyres and 255/35 R 19 rear tyres (option; available as wheel 605 for Mercedes-AMG C 43)¹

665 AMG multi-spoke light-alloy wheels, painted high-gloss black with a high-sheen finish, with 225/40 R 19 front tyres and 255/35 R 19 rear tyres (option; available as wheel 606 for Mercedes-AMG C 43)¹

604 AMG 5-twin-spoke light-alloy wheels, painted high-gloss black with a high-sheen finish, with 225/40 R 19 front tyres and 255/35 R 19 rear tyres; also available as wheel 644 painted titanium grey with a high-sheen finish²

609 AMG 10-spoke light-alloy wheels, painted titanium grey with a high-sheen finish, with 255/40 R 18 front tyres and 285/35 R 18 rear tyres³

601 AMG 5-twin-spoke light-alloy wheels, painted titanium grey with a high-sheen finish, with 255/35 R 19 front tyres and 285/30 R 19 rear tyres^{4,5}

770 AMG cross-spoke forged wheels, painted titanium grey with a high-sheen finish, with 255/35 R 19 front tyres and 285/30 R 19 rear tyres; also available as wheel 766 with 285/30 R 20 rear tyres⁶

662 AMG cross-spoke forged wheels, painted matt black with a high-sheen finish, with 255/35 R 19 front tyres and 285/30 R 19 rear tyres; also available as wheel 767 with 285/30 R 20 rear tyres⁶

RXC AMG performance 5-twin-spoke forged wheels, painted matt black with a high-sheen finish, with 255/35 R 19 front tyres and 285/30 R 20 rear tyres⁷

FURTHER WHEELS

are available from our accessories range at www.mercedes-benz-accessories.com or your authorised Mercedes-Benz dealer.

¹ Not available for Mercedes-AMG C 63/C 63 S. ² Option for Mercedes-AMG C 43 4MATIC. ³ Standard for Mercedes-AMG C 63. ⁴ Standard for Mercedes-AMG C 63 S. ⁵ Option for Mercedes-AMG C 63.

⁶ Option for Mercedes-AMG C 63/C 63 S. ⁷ Option for Mercedes-AMG C 63 S.

Never stop challenging: Mercedes-AMG C-Class Coupé and Cabriolet.

Mercedes-AMG is not just a producer of performance vehicles and sports cars, AMG is a promise. A promise to always seek out new challenges and go one step further. To expect a lot and give everything. This is how we create extraordinary cars for extraordinary people.

The new Mercedes-AMG C-Class Coupés and Cabriolets – from the C 43 to the C 63 S – likewise stand for the aspiration to get the most. Out of every moment, out of every metre.

Welcome to the world of AMG.



DESIGN





Adrenaline in its most attractive form.

Special moments often start when your heart starts racing – even prior to getting in. The Mercedes-AMG C 63 Coupé may exude many things at first sight – but reserve isn't one of them. Powerdomes on the bonnet, the A-wing front apron design exclusive to AMG, striking double louvres with “AMG” lettering in the radiator grille. And with its clearly wider body, you may happily draw conclusions from its exterior appearance about its inner workings – the abilities of this top athlete live up to the promise implicit in its looks: unadulterated performance.



We've managed to accelerate the braking process.

Those who go their own way have to be strong – but power is nothing without control: the AMG high-performance braking system for the Mercedes-AMG C 63 Coupé is equipped with internally ventilated and perforated brake discs all round, ensuring outstanding deceleration. The optional AMG ceramic high-performance composite braking system adds braking performance of the kind seen in motorsport and is around 30% lighter than the standard-fit braking system. There really is no stopping our engineers when it comes to giving everything. So that you can give everything, too.



SILOS CO

CAUTION
RESTRICTED
AREA

CAUTION
RESTRICTED
AREA

DOT LMOF BXXF 4515 E4

AMG

AMG

A burning desire for perfection. With 375 kW (510 hp).



One second. The 4.0-litre V8 biturbo engine at the heart of the C 63 S develops its full power. Two seconds. The electronically controlled limited-slip differential distributes the engine power to the rear axle and affords the two 20-inch wheels optimum traction. Three seconds. The AMG SPEEDSHIFT MCT 7-speed sports transmission with Race Start function fires through the gears in next to no time. Three point nine seconds. 100 km/h – and you experience sheer automotive passion.



More power. More passion. Less compromise.

Built for extremes: straining at the leash beneath the bonnet of the Mercedes-AMG C 63 Coupé is an all-new AMG 4.0-litre V8 biturbo engine. Once awoken, the compact unit with an output of up to 375 kW (510 hp) and a torque of 700 Nm in the S-Model will earn the respect of any drivers' paddock. Every engine for the C 63 models is produced based on the AMG "One Man – One Engine" philosophy. By all means take the signature of the technician on the engine badge as a promise: every AMG is built out of passion – for even more performance.

DRIVE





Performance as standard.

One line-up, three first places. As easy as it is to be excited by this array of talent, choosing a favourite model is difficult. Because all Mercedes-AMG C-Class Coupés and Cabriolets belong to an exclusive group of cars systematically configured for exacting performance. With its AMG genes and its powerful V6 engine, the Mercedes-AMG C 43 makes it easy for ambitious drivers to gain access to the world of AMG. Even more power and exclusivity are available in the shape of the Mercedes-AMG C 63 and C 63 S Coupés and Cabriolets. Whether Coupé or Cabriolet, each of these models is underpinned by a true motor-racing feel. After all, performance is the best of companions.





Engine and performance	Mercedes-AMG C 63 S Coupé/Cabriolet	Mercedes-AMG C 63 Coupé/Cabriolet	Mercedes-AMG C 43 Coupé/Cabriolet
Engine	AMG 4.0-litre V8 biturbo	AMG 4.0-litre V8 biturbo	3.0-litre V6 biturbo
Displacement (cc)	3982	3982	2996
Output (kW/hp)	375/510	350/476	270/367
Torque (Nm at rpm)	700 at 1750-4500	650 at 1750-4500	520 at 2000-4200

Eye-catcher.

It's not just the inner values that count. The distinctive design of the Mercedes-AMG C 63 Cabriolet sets new standards. The front apron with the powerful air intakes in A-wing design and the sharp, dynamic side line follow a clear design idiom. A systematically sculpted driving machine with unique lines that becomes even more eye-catching when the roof comes down.





Power in a new form.

The C 63 Cabriolet challenges observers from every angle – and impresses with distinctive details. Such as the broad, muscular rear end with three diffuser fins or the optional adjustable AMG performance exhaust system that provides an impressive soundtrack for the car’s powerful performance. The source of this sound and a guarantee of seemingly endless forwards thrust: the all-new AMG 4.0-litre V8 biturbo engine, developing 375 kW (510 hp) and a torque of 700 Nm in the S-Model, leaving any would-be challengers very little chance indeed.



DYNAMISM





By open-minded thinkers. For open-minded drivers.

If the Race drive mode is selected using AMG DYNAMIC SELECT, the Electronic Stability Program (ESP®) switches to Sport Handling Mode and allows later ESP® intervention as well as more drive torque on the rear axle. With the top down, you get to feel the full agility of the sporty Cabriolet model even more intensely.





True values come from inside.

The best thing about taking a time-out is setting a new best time afterwards. The optional AMG performance seats in the C 63 Cabriolet fit like a glove and offer optimum lateral support even when cornering at high speed. Together with the precise feedback from the speed-sensitive sports steering, everything is prepared as far as we're concerned. Are you prepared, too?

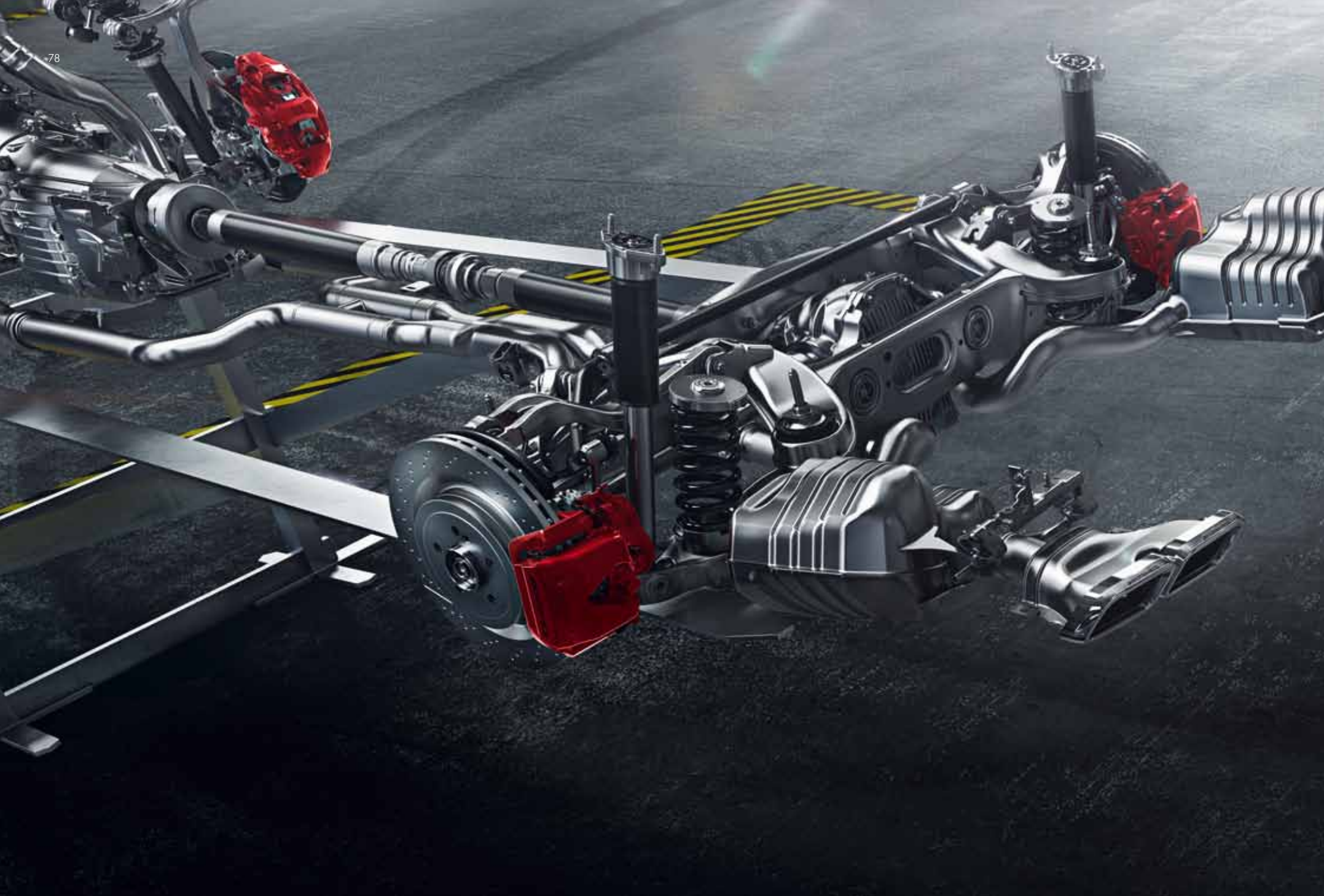

A detailed view of a Mercedes-AMG 8-cylinder engine, likely an M109, mounted on a metal stand in a workshop. The engine is highly detailed, showing various components like the intake manifold, belts, and cooling fans. The AMG logo is visible on the black valve covers. The background shows a grey concrete floor with yellow and black striped safety tape and a metal toolbox on the right.

Racing technologies. Now licensed for the road.

The rear axle developed specifically for the Mercedes-AMG C 63 Coupé and the C 63 Cabriolet combines with the wider tyres to deliver even more driving dynamics. The mechanically controlled AMG rear axle limited-slip differential improves traction in every driving situation, especially when the driver adopts a sporty driving style. In the S-Model, an electronic limited-slip differential with variable locking effect delivers faster and even more precise control. The result is even greater traction and higher cornering speeds. The AMG RIDE CONTROL sports suspension offers an adaptive adjustable electronic damping system with three settings at the touch of a button. So the car is always ideally primed for the road ahead – and for whatever mood you happen to be in. Another development highlight comes in the shape of our 8-cylinder engines: a concentrated bundle of energy – yet restrained when it comes to fuel consumption and emissions. This is how AMG sets new standards. And not just on the racetrack.





Passion grows when it is shared: the AMG Private Lounge is our Community centred around the world of AMG. This is where AMG customers meet at top-class events and on the online platform exchange views about the latest developments from Affalterbach. They benefit from special offers and from a direct connection with the AMG headquarters: www.mercedes-amg.com/privatelounge/welcome

The AMG Driving Academy stands for an incomparable team spirit: experience performance with like-minded drivers and improve your driving skills on racetrack and lifestyle events held at breathtaking locations around the world. Become a part of the “World’s Fastest Family”: www.mercedes-amg.com/driving-academy

Do you desire even more? With the AMG Customer Sports Programme, AMG offers a platform for professional motorsport – and with the Mercedes-AMG GT3 a racing car designed specifically for this purpose. A fully integrated service package allows you to take part in high-level motorsport: www.mercedes-amg.com/customersports

In the AMG Performance Studio we create cars that are perfectly tailored to your wishes and desires. No limits are placed on our experts’ creativity, who demonstrate their unparalleled craftsmanship and attention to detail in areas as varied as special technical components, extravagant paintwork finishes and the most exclusive interior appointments imaginable, to produce one-off masterpieces.

Enter the world of AMG. Experience true driving performance.

We don't just build cars.
We make dreams come true.

Technical data for Coupé.

No. of cylinders/arrangement
Total displacement in cc
Rated output ¹ in kW (hp) at rpm
Rated torque ¹ in Nm at rpm
Acceleration from 0 to 100 km/h in s
Top speed, approx. in km/h
Fuel consumption ³ in l/100 km
Urban
Extra-urban
Combined
CO ₂ emissions ³ in g/km combined
Emission class ⁴ /efficiency class ⁵

No. of cylinders/arrangement
Total displacement in cc
Rated output ¹ in kW (hp) at rpm
Rated torque ¹ in Nm at rpm
Acceleration from 0 to 100 km/h in s
Top speed, approx. in km/h
Fuel consumption ³ in l/100 km
Urban
Extra-urban
Combined
CO ₂ emissions ³ in g/km combined
Emission class ⁴ /efficiency class ⁵

The best for the engine:
Mercedes-Benz genuine engine oils.

Diesel engines

C 220 d	C 220 d 4MATIC	C 250 d	C 250 d 4MATIC
4/in-line	4/in-line	4/in-line	4/in-line
2143	2143	2143	2143
125 (170)/3000-4200	125 (170)/3000-4200	150 (204)/3800	150 (204)/3800
400/1400-2800	400/1400-2800	500/1600-1800	500/1600-1800
7.8 [7.5]	- [7.6]	- [6.7]	- [6.9]
234 [234]	- [230]	- [247]	- [240]
5.3-5.0 [5.7-5.4]	- [5.8-5.4]	- [5.5-5.0]	- [5.8-5.4]
3.9-3.6 [4.2-3.7]	- [4.6-4.2]	- [4.5-4.0]	- [4.6-4.2]
4.4-4.1 [4.7-4.4]	- [5.0-4.6]	- [4.8-4.4]	- [5.0-4.6]
116-106 [124-112]	- [132-122]	- [127-115]	- [132-122]
Euro 6/A+ [Euro 6/A+]	- [Euro 6/A]	- [Euro 6/A+]	- [Euro 6/A]

Petrol engines

C 200 4MATIC	C 250	C 300	C 400 4MATIC	Mercedes-AMG C 43 4MATIC	Mercedes-AMG C 63	Mercedes-AMG C 63 S
4/in-line	4/in-line	4/in-line	6/V	6/V	8/V	8/V
1991	1991	1991	2996	2996	3982	3982
135 (184)/5500	155 (211)/5500	180 (245)/5500	245 (333)/5250-6000	270 (367)/5500-6000	350 (476)/5500-6250	375 (510)/5500-6250
300/1200-4000	350/1200-4000	370/1300-4000	480/1600-4000	520/2000-4200	650/1750-4500	700/1750-4500
- [7.5]	- [6.8]	- [6.0]	- [4.9]	- [4.7]	- [4.0]	- [3.9]
- [229]	- [250] ²	- [250] ²	- [250] ²	- [250] ²	- [250] ²	- [250] ²
- [9.2-8.8]	- [8.0-7.5]	- [8.7-8.3]	- [10.9-10.6]	- [10.8-10.6]	- [11.9-11.4]	- [11.4]
- [6.1-5.7]	- [5.3-4.7]	- [5.7-5.1]	- [6.2-5.8]	- [6.4-6.2]	- [7.1-6.9]	- [6.9]
- [7.2-6.8]	- [6.3-5.8]	- [6.8-6.3]	- [8.0-7.6]	- [8.0-7.8]	- [8.9-8.6]	- [8.6]
- [162-153]	- [141-130]	- [154-143]	- [181-172]	- [183-178]	- [209-200]	- [200]
- [Euro 6/C]	- [Euro 6/B]	- [Euro 6/B]	- [Euro 6/D]	- [Euro 6/D]	- [Euro 6/E]	- [Euro 6/E]

¹ Figures for rated output and rated torque according to Regulation (EC) No. 595/2009 as amended. ² Electronically governed. ³ The indicated figures for fuel consumption and CO₂ emissions were determined according to the specified measuring process (§ 2 nos. 5, 6, 6a Pkw-EnVKV (German Passenger Car Labelling Ordinance) as amended). The figures are not based on an individual model and do not constitute part of the product offer; they are

Petrol engines

C 180	C 200
4/in-line	4/in-line
1595	1991
115 (156)/5300	135 (184)/5500
250/1250-4000	300/1200-4000
8.5 [8.8]	7.7 [7.3]
225 [223]	237 [240]
7.2-6.8 [7.8-7.5]	7.5-6.8 [7.9-7.5]
5.0-4.4 [5.4-4.9]	4.9-4.4 [5.2-4.7]
5.8-5.3 [6.3-5.9]	5.9-5.3 [6.2-5.8]
135-122 [142-132]	136-123 [140-129]
Euro 6/B [Euro 6/B]	Euro 6/A [Euro 6/A]

Technical data for Cabriolet.

	Diesel engines			Petrol engines		
	C 220 d	C 220 d 4MATIC	C 250 d	C 180	C 200	C 200 4MATIC
No. of cylinders/arrangement	4/in-line	4/in-line	4/in-line	4/in-line	4/in-line	4/in-line
Total displacement in cc	2143	2143	2143	1595	1991	1991
Rated output ¹ in kW (hp) at rpm	125 (170)/3000-4200	125 (170)/3000-4200	150 (204)/3800	115 (156)/5300	135 (184)/5500	135 (184)/5500
Rated torque ¹ in Nm at rpm	400/1400-2800	400/1400-2800	500/1600-1800	250/1200-4000	300/1200-4000	300/1200-4000
Acceleration from 0 to 100 km/h in s	8.3 [8.2]	- [8.1]	- [7.2]	8.9 [8.9]	8.2 [7.8]	- [8.0]
Top speed, approx. in km/h	231 [231]	- [225]	- [243]	222 [220]	235 [233]	- [227]
Fuel consumption ³ in l/100 km						
Urban	5.7-5.4 [5.7-5.2]	- [6.1-5.8]	- [5.7-5.2]	7.8-7.6 [7.9-7.7]	7.7-7.5 [8.1-7.8]	- [9.5-9.1]
Extra-urban	4.3-3.9 [4.8-4.3]	- [4.9-4.7]	- [5.0-4.3]	5.4-5.1 [5.7-5.3]	5.5-5.1 [5.5-5.1]	- [6.5-6.1]
Combined	4.8-4.5 [5.2-4.6]	- [5.3-5.0]	- [5.2-4.6]	6.3-6.0 [6.5-6.2]	6.3-6.0 [6.5-6.1]	- [7.5-7.2]
CO ₂ emissions ³ in g/km combined	126-116 [133-121]	- [140-130]	- [133-121]	143-135 [149-140]	143-136 [147-138]	- [171-162]
Emission class ⁴ /efficiency class ⁵	Euro 6/A+ [Euro 6/A+]	- [Euro 6/A]	- [Euro 6/A+]	Euro 6/B [Euro 6/B]	Euro 6/B [Euro 6/B]	- [Euro 6/C]

	Petrol engines					
	C 250	C 300	C 400 4MATIC	Mercedes-AMG C 43 4MATIC	Mercedes-AMG C 63	Mercedes-AMG C 63 S
No. of cylinders/arrangement	4/in-line	4/in-line	6/V	6/V	8/V	8/V
Total displacement in cc	1991	1991	2996	2996	3982	3982
Rated output ¹ in kW (hp) at rpm	155 (211)/5500	180 (245)/5500	245 (333)/5250-6000	270 (367)/5500-6000	350 (476)/5500-6250	375 (510)/5500-6250
Rated torque ¹ in Nm at rpm	350/1200-4000	370/1300-4000	480/1600-4000	520/2000-4200	650/1750-4500	700/1750-4500
Acceleration from 0 to 100 km/h in s	- [6.9]	- [6.4]	- [5.2]	- [4.8]	- [4.2]	- [4.1]
Top speed, approx. in km/h	- [244]	- [250] ²	- [250] ²	- [250] ²	- [250] ²	- [250] ²
Fuel consumption ³ in l/100 km						
Urban	- [8.2-7.8]	- [8.9-8.6]	- [11.2-10.9]	- [11.2-11.0]	- [12.4-12.0]	- [12.0]
Extra-urban	- [5.7-5.2]	- [6.0-5.6]	- [6.6-6.3]	- [6.9-6.7]	- [7.5-7.2]	- [7.2]
Combined	- [6.6-6.2]	- [7.1-6.7]	- [8.3-8.0]	- [8.4-8.3]	- [9.3-8.9]	- [8.9]
CO ₂ emissions ³ in g/km combined	- [150-140]	- [161-151]	- [189-181]	- [194-190]	- [218-208]	- [208]
Emission class ⁴ /efficiency class ⁵	- [Euro 6/B]	- [Euro 6/B]	- [Euro 6/D]	- [Euro 6/D]	- [Euro 6/E]	- [Euro 6/E]

provided solely for purposes of comparison between the different vehicle models. ⁴ Data applicable within the European Union only. May vary from country to country. ⁵ Determined on the basis of the measured CO₂ emissions, taking into account the mass of the vehicle. Figures in square brackets refer to engines in conjunction with optional automatic transmission. Further technical data available at www.mercedes-benz.com

Coupé dimensions.

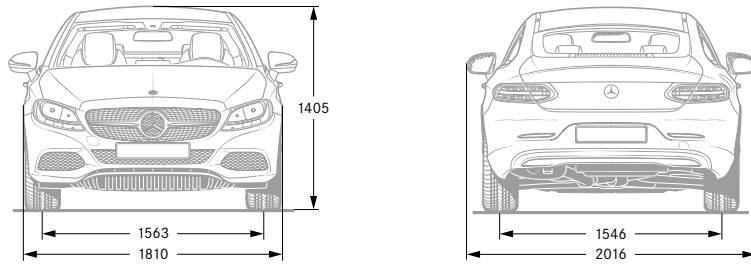

Cabriolet dimensions.

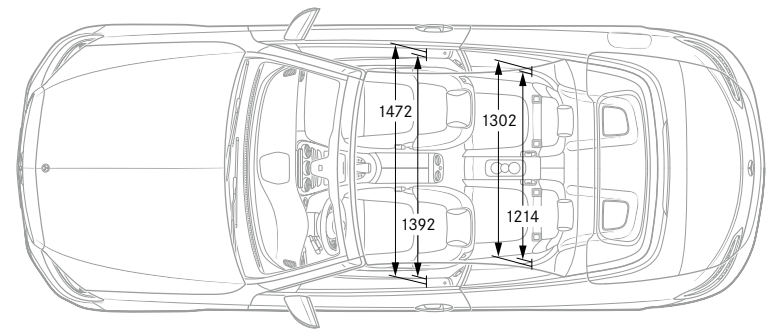
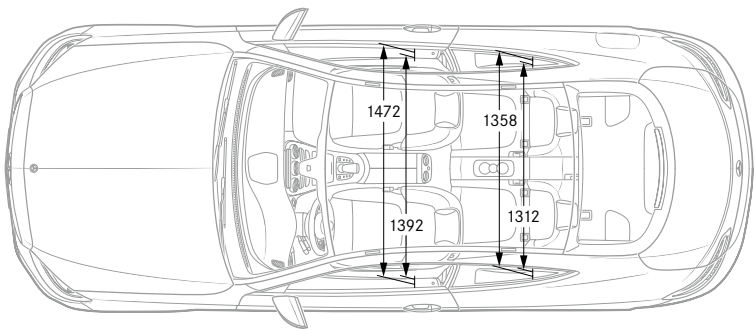
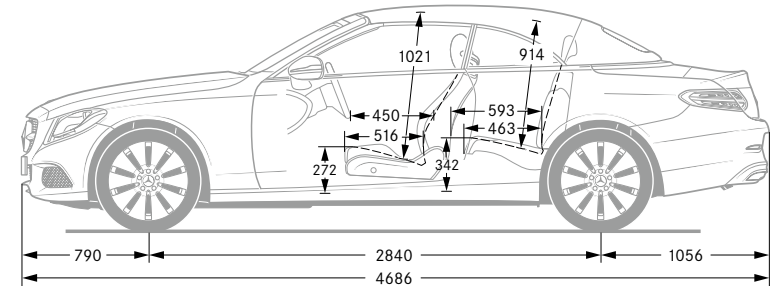
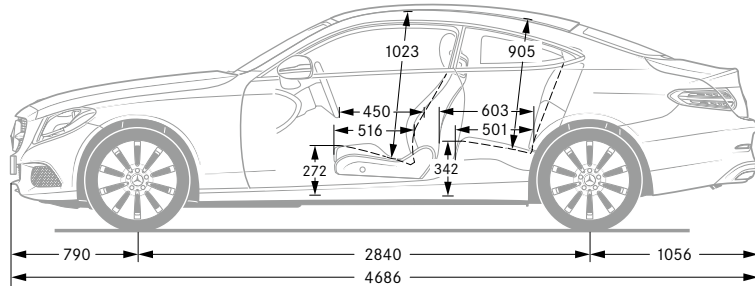
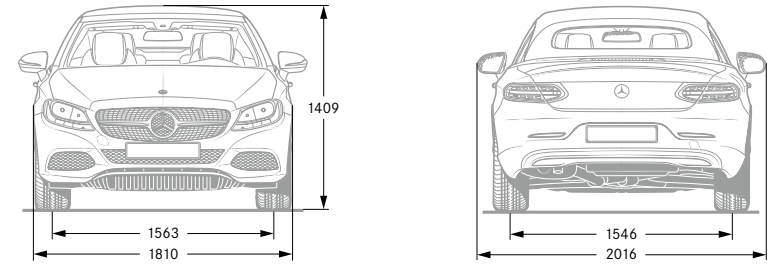

All dimensions in millimetres. The dimensions shown are mean values and apply to standard-specification, unladen vehicles.

Upholstery and trim.

Upholstery

301	black ^{1,2}
101	black ^{1,2,3}
105	silk beige/black ^{1,2,3}
118	crystal grey/black ^{1,2,3}
124	saddle brown/black ^{1,2,3}
201	black ^{2,3}
218	crystal grey/black ^{2,3}
224	saddle brown/black ^{2,3}
225	porcelain/black ^{2,3}
227	cranberry red/black ^{2,3}
241	black ^{2,4}
611	black ^{5,6}
621	black ⁷
651	black ⁸
641	black ⁹
654	nut brown/black ¹⁰
801	black ^{6,11}
811	black ⁶
851	platinum white pearl/black ^{6,11}
857	red pepper/black ^{6,11}
967	Bengal red/black ^{1,2,3}

Trim

H73	AMG carbon fibre/light longitudinal-grain aluminium ³
H84	AMG matt silver glass fibre/light longitudinal-grain aluminium ³
739	black piano-lacquer look/light longitudinal-grain aluminium ^{3,5,7,9}
H09	brown open-pore ash wood ^{1,2,3}
736	black open-pore ash wood/light longitudinal-grain aluminium ^{4,6,8,11}
H07	high-gloss brown linestructure lime wood ³
H80	black piano-lacquer look ^{1,2}

¹ Not available for Mercedes-AMG C 43 4MATIC. ² Not available for Mercedes-AMG C 63/63 S. ³ Optional extra. ⁴ Optional extra for Mercedes-AMG C 43 4MATIC. ⁵ Standard for Mercedes-AMG C 63. ⁶ Optional extra for Mercedes-AMG C 63 S. ⁷ Standard for Mercedes-AMG C 63 S. ⁸ Standard in conjunction with AMG Line interior. ⁹ Standard for Mercedes-AMG C 43 4MATIC. ¹⁰ Part of optional Style package for Mercedes-Benz C-Class Coupé. ¹¹ Optional extra for Mercedes-AMG C 63.

ARTICO man-made leather/

Norwich fabric



ARTICO man-made leather

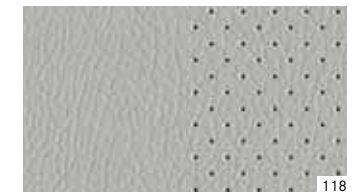
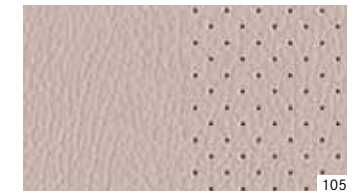

Leather, sun-reflecting

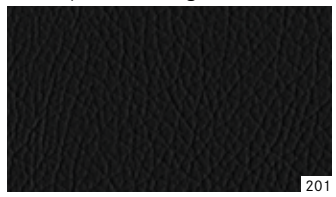

201



218



224



225



227



241

ARTICO man-made leather/
DINAMICA microfibre



611
621
651



641

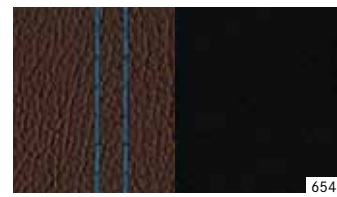

654

AMG nappa leather,
sun-reflecting



801
811



851



857

designo nappa leather,
sun-reflecting



967

Trim

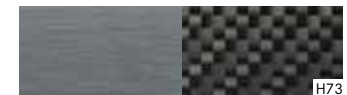

H73



H84



739



H09



736



H07



H80

Paintwork.

Non-metallic paints



040

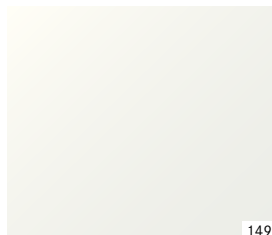

149

Metallic paints²



197



775



796



890



896



988



992

designo paints²



049



297



799



982



996

Soft-top colours



740



741



742



744

Non-metallic paints

- 040 black¹
149 polar white

Metallic paints²

- 197 obsidian black
775 iridium silver
796 citrine brown¹
890 cavansite blue¹
896 brilliant blue
988 diamond silver¹
992 selenite grey

designo paints²

- 049 designo cashmere white magno³
297 designo selenite grey magno⁴
799 designo diamond white bright
982 designo iridium silver magno⁵
996 designo hyacinth red metallic⁶

Soft-top colours

- 740 black fabric soft top^{7,8}
741 dark brown fabric acoustic soft top⁸
742 dark red fabric acoustic soft top⁸
744 dark blue fabric acoustic soft top⁸

¹ Not in conjunction with Mercedes-AMG C 63/C 63 S. ² Optional extra. ³ Only in conjunction with Mercedes-AMG C 63/C 63 S Cabriolet.

⁴ Not in conjunction with Mercedes-AMG C 63/C 63 S Cabriolet. ⁵ Only in conjunction with Mercedes-AMG C 63/C 63 S Coupé. ⁶ Not in conjunction with Mercedes-AMG C 63/C 63 S Coupé. ⁷ black fabric soft top as standard. ⁸ Fabric acoustic soft top (Code 6U1) as optional extra.



Mercedes-Benz is one of the founding partners of the “Laureus Sport for Good Foundation”.

Since the foundation was established in 2000, Mercedes-Benz has been supporting and promoting the aims and values of this worldwide non-profit-making programme: to use social sports projects to improve the lives of children and young people who are disadvantaged or suffering from illness. Laureus has become a fundamental element of Mercedes-Benz’s social responsibility. Every new Mercedes is an ambassador embodying these values. In buying a Mercedes you are supporting the “Laureus Sport for Good Foundation”.

Please note: changes may have been made to the product since this brochure went to print (08.08.2016). The manufacturer reserves the right to make changes to the design, form, colour and specification during the delivery period, provided these changes, while taking into account the interests of the vendor, can be deemed reasonable with respect to the purchaser. Where the vendor or the manufacturer uses symbols or numbers to describe an order or the subject of an order, no rights may be derived solely from these. The illustrations may show accessories and optional extras which are not part of standard specification. Colours may differ slightly from those shown, owing to the limitations of the printing process. This brochure is distributed internationally. Information given regarding statutory regulations, legal requirements and taxation and the consequences thereof applies to the Federal Republic of Germany only and is correct at the time of going to print. For current and more specific information in relation to the range of models, features, optional extras, colours and/or services available in your country, and their pricing, you should contact your nearest authorised Mercedes-Benz Passenger Car Dealer.

www.mercedes-benz.com

Daimler AG, Mercedesstr. 137, 70327 Stuttgart MS/MAC 6701 · 0355 · 02-01/1216

Take-back of end-of-life vehicles. At the end of its long life, you can return your C-Class Coupé or Cabriolet to us for environment-friendly disposal in accordance with the European Union (EU) End-Of-Life Vehicle Directive. But that day lies a long way off.

A network of vehicle take-back depots and dismantlers has been established to make it as easy as possible for you to return your vehicle. You can leave it at any of these points free of charge and, by so doing, make a valuable contribution to completing the recycling process and conserving resources.

For further information about the recycling and disposal of end-of-life vehicles and take-back conditions, please visit your national Mercedes-Benz website.